

<THESE INSTRUCTIONS MUST BE GIVEN TO THE END USER>

B&W Trailer Hitches



Turnoverball™ Gooseneck Hitch Installation Instructions

MODEL 1116 & 1117

GNRK 1116: 2017 Ford F250 & 350, Super Duty, 2 Wheel Drive
 GNRK 1117: 2017 Ford F250 & 350, Super Duty, 4 Wheel Drive
 2017 Ford F450, 4 Wheel Drive with Factory Installed Bed

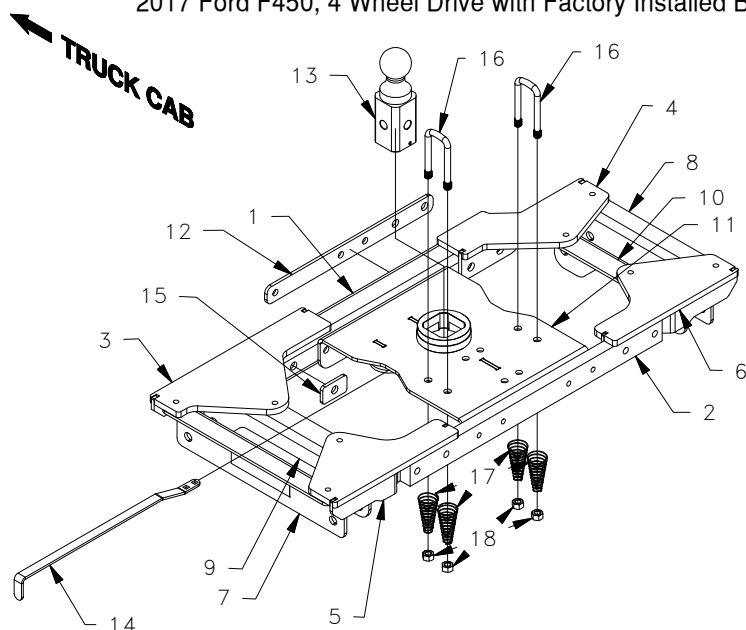

Mounting Kit Box (GNRM1117)		
ITE	DESCRIPTION	QTY
1	Front Cross Member	1
2	Rear Cross Member	1
3	Cross Member Bracket Front Driver	1
4	Cross Member Bracket Front Passenger	1
5	Cross Member Bracket Rear Driver	1
6	Cross Member Bracket Rear Passenger	1

Hardware Bolt Bag 1		
ITEM	DESCRIPTION	QTY
15	Rectangle Washer	1
	1/2" X 1 1/2" Cap Screw w/ Pre-Applied Thread Lock	8
	1/2" x 1 1/2" Cap Screw	4
	1/2" Finish Nut	4
	1/2" Flat Washer	16
	1/2" Lock Washer	16
	1/2" X 4" Cap Screw	4
	5/8" X 1 1/2" Cap Screw	4
	5/8" Finish Nut	7
	5/8" Lock Washer	11

Center Box (GNRC816 & GNRC817)		
ITEM	DESCRIPTION	QTY
7	Outer Driver Sideplate	1
8	Outer Passenger Sideplate	1
9	Inner Driver Sideplate (GNRC816 Only)	1
10	Inner Passenger Sideplate (GNRC816 Only)	1
11	Center Section	1
12	Washer Plate	1
13	2-5/16" Ball	1
14	Latch Pin Handle	1

Hardware Bolt Bag 2		
ITEM	DESCRIPTION	QT
16	1/2" U-Bolt	2
17	Conical Springs	4
18	1/2" Lock Nut	4
	5/16" X 3/4" Carriage Bolt	2
	5/16" Flange Lock Nut	2
	5/8" Flat Washer	12
	5/8" X 4" Cap Screw	7

⚠️ WARNING

Failure to comply with the safety information in these instructions could result in serious injury or death.

- ⚠️ Read all installation and operating instructions along with all labels before using this product.
- ⚠️ Without proper knowledge, towing can be a dangerous activity. Understand all the risks involved with towing before proceeding. For information on towing safety, see **"The Trailer Handbook: A Guide to Understanding Trailer and Towing Safety"** from the National Association of Trailer Manufacturers.
- ⚠️ The Turnoverball hitch comes equipped with a 2-5/16" ball. Trailers towed with the ball provided must have a 2-5/16" coupler. Towing with a larger coupler could cause loss of attachment between the trailer and the tow vehicle.
- ⚠️ This product was designed to fit vehicles in their original, "as manufactured" condition. Compatibility with vehicles having replacement parts, or other modifications is not guaranteed. Inspect vehicle for modifications before installation of this product.
- ⚠️ Do not exceed tow or tongue rating of coupler, tow or tongue rating of hitch, or tow or weight ratings of truck or trailer. See vehicle and trailer manufacturer information for ratings. Exceeding these ratings may cause damage to towing components or loss of attachment between the trailer and truck.
- ⚠️ Adding components such as a Turnoverball hitch to the chassis of any vehicle can be hazardous. There is potential for unexpected combustion of fuel, electric shock, burns, shifting or falling of unstable vehicle, damage to vehicle, injury from tool usage and many other hazards. This installation must be completed by someone who is aware of the hazards involved. This person must be knowledgeable of proper safety procedures for a vehicle modification of this nature, and for usage of the equipment required to perform the installation.
- ⚠️ Do not modify this product in any manner. Doing so could alter its integrity and lead to a loss of attachment between the trailer and the tow vehicle.

PREPARING TO INSTALL

NOTE: Remove all parts from the packaging and familiarize yourself with all the parts and tools required. Use the parts list on the front page to verify that all parts and hardware are present.

Installation of the Turnoverball hitch requires several common tools and a few specialized tools. Below is a listing of equipment used during a typical installation.

TOOLS REQUIRED

- Impact wrench or ratchet with 3/4" & 15/16" sockets.
- 1/2", 3/4" & 15/16" Box end wrench
- Marking tool (pencil or permanent marker)
- 4" hole saw
- Drill with 1/2" bit
- Ear protection
- Pry Bar
- Lifting Device
- Flashlight
- Eye protection
- Torque wrench
- Tape measure
- Pilot hole Bit

1. **Determine cab clearance.** The Turnoverball hitch is designed so that the ball can be inverted and stored below the surface of the truck bed while not in use. The ball location is determined by this design feature and the truck geometry. Measure the trailers to be towed with this hitch to be sure that the location of the 2-5/16" ball listed in step 5 will provide ample turning clearance between the nose of the trailers and the cab of the truck.

⚠ Cab clearance on short bed trucks is very limited when towing certain trailers. Failure to ensure that there will be adequate clearance, may result in significant property damage, or serious injury.

2. **Remove the spare tire (optional).** Following the vehicle manufacturer's instructions, remove the spare tire. This will provide easier access to the area where the hitch will be installed.

3. **Position the vehicle.** Installation of the hitch requires the installer to be under the truck bed in the area of the rear axle. Lifting the vehicle makes this area more accessible to the installer, and improves the installation process.

⚠ WARNING: Lift vehicle using only equipment designed for lifting and positioning vehicles for service. Failure to do so may result in property damage, serious injury, or death.

4. **Prepare a lifting device (optional).** The purpose of the device is to safely hold the hitch in position during part of the installation. See Figure A1 for an example. A simple mechanical lifting device is available for purchase from B&W.

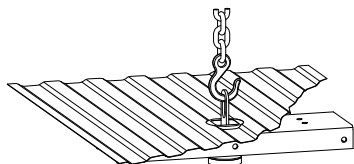

Figure A1

5. **Mark the 4" hole location.** Using a tape measure hooked over the rear edge of the bed (at tailgate end), measure the location for the hole as shown in Figure A2. Next, locate the center of the bed by measuring the distance between the wheel wells and dividing by two. The center of the hole will be at the intersection of the center of the bed and the first distance measured.

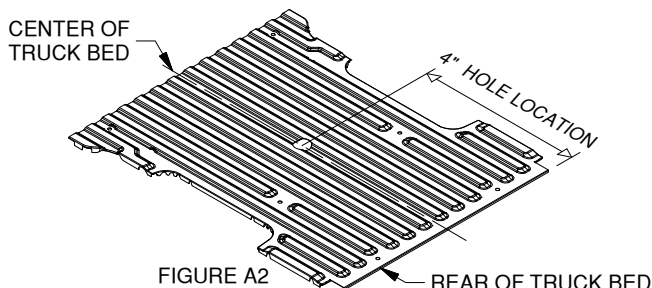

FIGURE A2

4" HOLE LOCATION

8' LONG BED AND SHORT BED (BED LESS THAN 8' LONG) - 45-3/4"

IMPORTANT: The hitch is designed to install only at the described location. Failure to place the 4" hole precisely may result in added difficulty during installation or property damage.

6. **Cut the 4" diameter hole.** Cut the hole in the marked location using a 4" hole saw or by marking out the 4" hole and using a saber saw equipped with a metal cutting blade. Remove any burrs created while cutting hole.

IMPORTANT: If the bed is equipped with a plastic bed liner, the hole may be cut through both the liner and the bed. However, the center of truck bed may be more difficult to locate, and the mark may be harder to hit if the liner slides or moves. Failure to cut the hole in the correct location may adversely affect the install and may result in property damage.

IMPORTANT: If your truck has a spray-in bed liner you will need to take this into account when you are measuring, and add the thickness of the applied liner that has been sprayed over the end of the bed.

7. **Optional, lower the tail pipe.** On some trucks installation may be easier if exhaust is detached and the tail pipe lowered. Un-attach the tail pipe bracket just behind the rear passenger side tire, see Figure A3. Re-attach the tail pipe bracket after installation is complete.

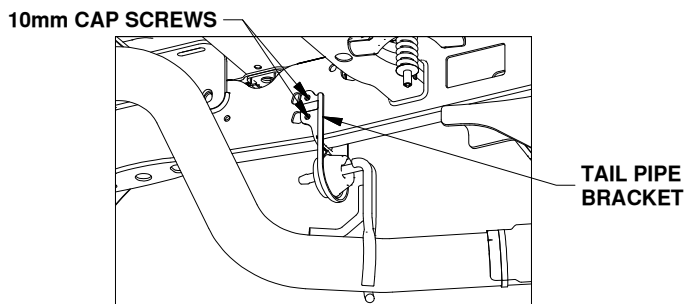

Figure A3: View looking at the tail pipe on rear passenger side of frame.

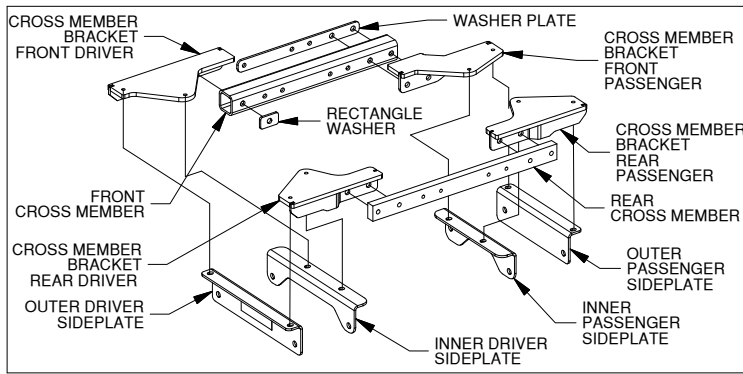

Figure B1: Sideplates and Mounting Kit Exploded View

⚠ Turnoverball hitch components are heavy and may be cumbersome to handle. Failure to use proper lifting techniques and caution when handling these items could result in serious injury.

⚠ Most trucks have fuel lines, brake lines, electrical wires or other vehicle systems located along the frame rails or in the general area where B&W Turnoverball hitches install. Carefully examine the locations of these systems before installation. Make certain that these are not damaged during positioning hitch components, drilling holes, or tightening fasteners. Damage to these systems may result in property damage, serious injury, or death.

INSTALL SIDE PLATES & CROSS MEMBER BRACKETS.

1. **Note, steps 1-5.** Install hardware so it is snug, but do not fully tighten hardware connections at this time.

1. **Side Plates.** Each hitch install will require a set of inner side plates and a set of outer side plates. All 4-wheel drive trucks and some 2-wheel drive trucks come with inner side plates already welded to the frame. The hitch kit for 2-wheel drive trucks includes a set of inner side plates to be installed if the truck is not equipped with them.

2. **Install Side Plates.** Locate the outer and if needed the inner sideplates, see figure B1. Install the side plates as shown in Figures B2 & B3, so that there is a side plate on the inside and outside of each frame member. Attach the side plates to the frame using 5/8" x 4" bolts, two flat washers, lock washer, and nut, as shown in Figure B2. Fasten hardware until the side plates are flush against frame.

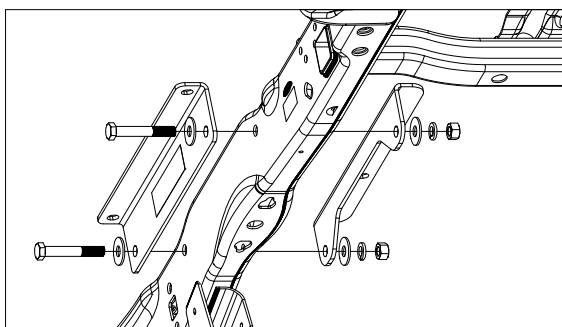

Figure B2: Driver Side Sideplates

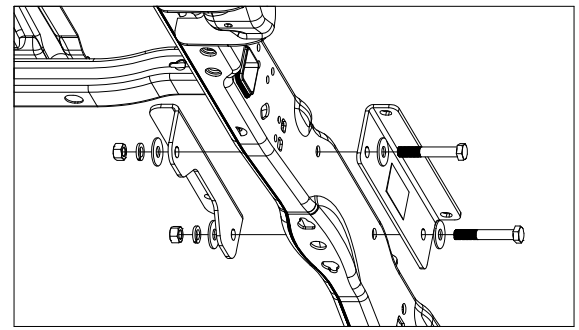

Figure B3: Passenger Side Sideplates

3. **Install Cross Member Brackets.** Locate the four cross member brackets as shown in Figure B1. Attach these brackets to the inner and outer sideplates and to the frame using the 1/2" X 1-1/2" bolts that have the thread locker pre-applied, a flat washer and lock washer as shown in Figures B4 & B5.

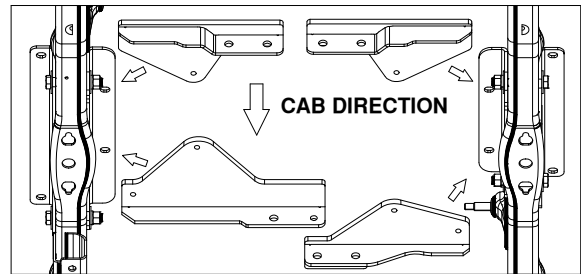

Figure B4: Bottom of truck frame looking up from the back of truck towards the cab

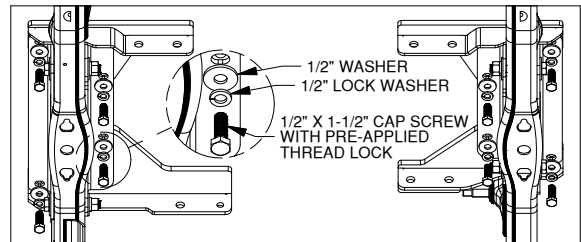

Figure B5: Bottom of truck frame looking up from the back of truck towards the cab

4. **Install Front Cross Member.** Locate the front cross member shown in Figure B1. Attach the front cross member, washer plate and two 5/8" X 4" bolts to the passenger side cross member bracket, see Figure B6. Next, attach the cross member to the driver side cross member bracket with 5/8" x 4" bolt, rectangle washer, lock washer and nut, see Figure B6.

5. **Install Rear Cross Member.** Locate the rear cross member shown in Figure B1. Attach the rear cross member to the cross member brackets as shown in Figure B6 with 5/8" x 1-1/2" bolts, flat washers, and nuts.

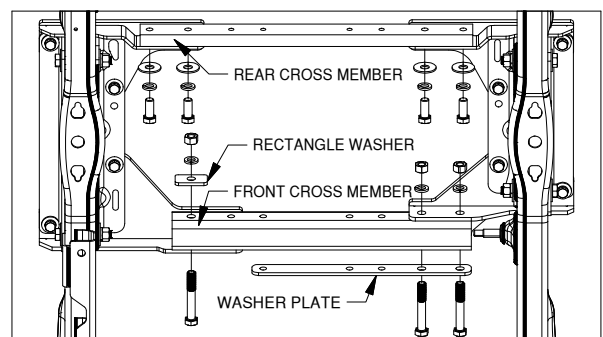

Figure B6: Bottom of truck frame looking up from the back of truck towards the cab

INSTALL CENTER SECTION

1. **Position Center Section.** Push the front cross member forward and the rear cross member rearward so that there is room between them for the center section. With the square holes of the latch mechanism on the driver side, lift the center into place as shown in Figure C1.

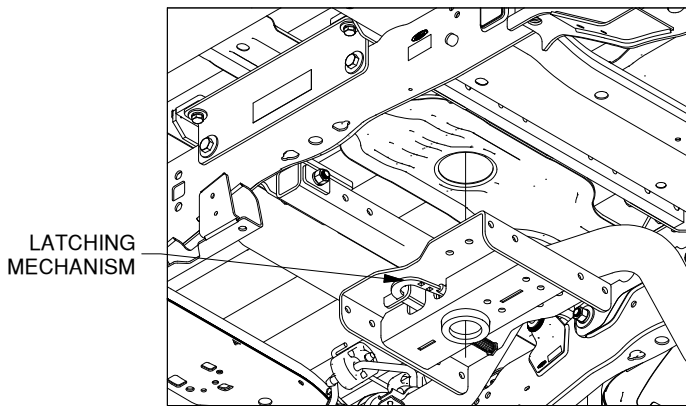

Figure C1: Bottom of truck frame looking up at hitch installation area.

2. **Install Hardware.** Attach the center to the front cross member by passing 1/2" x 4" bolts. Through the washer plate, and cross member and into the center section. Secure the bolts with flat washers, lock washers, and nuts. Next, attach the center to rear cross member with 1/2" x 1-1/2" bolts, flat washers, and lock washers, see Figure C2. Do not fully tighten hardware connections at this time.

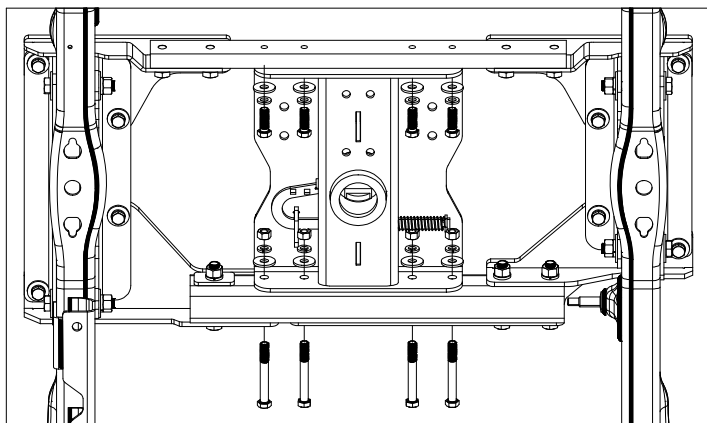

Figure C2: Bottom of truck frame looking up from the back of truck towards the cab

3. **Lifting Device.** A lifting device may be used to suspend the hitch below the truck bed in the correct position for securing the hardware. However, it is not needed to force center section against the bottom of the truck bed since this hitch does not contact the bed.

SECURE HITCH

IMPORTANT: The hitch must be square in the truck. If the latch pin is not parallel with the axle, certain accessories to the Turnoverball hitch will not be square with the truck.

1. **Step 1:** First, tighten the hardware attaching the cross members to the center section and each cross member bracket, see Figure D1
2. **Step 2:** Make sure all other hardware connections are tight enough to hold mating surfaces of parts flush but not tight enough to restrict movement for adjustment. Examine the socket from inside the truck bed through the 4" hole. Adjust the position of the hitch until the hitch cross members are parallel to the bed cross members and the socket is centered within the hole.
3. **Step 3:** Tighten the 1/2" x 1-1/2" bolt with the thread locker pre-applied between the passenger front cross member bracket and the passenger inside side plate. Next tighten the 1/2" x 1-1/2" bolt with thread locker between the driver rear cross member bracket and the driver inside side plate, see Figure D1. Examine the 4" hole again to be sure the socket is still centered in the hole.
4. **Step 4:** Once the hitch is properly located, tighten the remaining two bolts to the inside side plates. Then tighten the bolts with thread locker, that attach the outside side plates and the cross member brackets. Finally tighten the 5/8" bolts holding the side plates to the frame, see Figure D1.

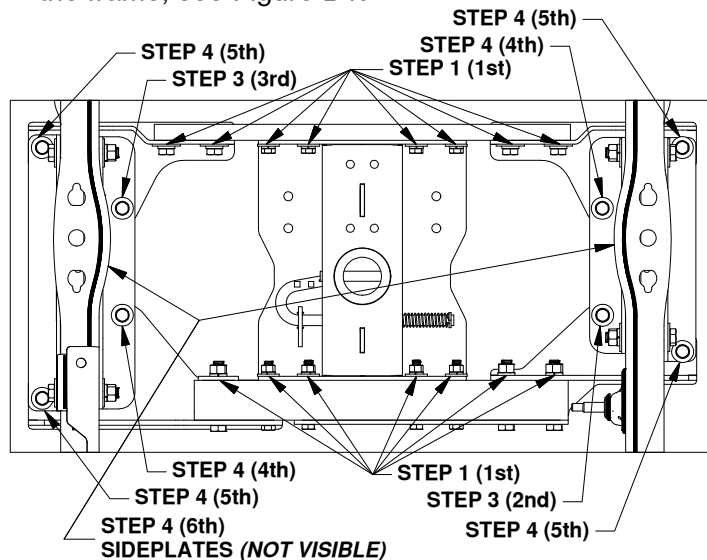

Figure D1: Bottom of truck frame looking up at hitch installation.

5. **Step 5:** Once hitch is tight, torque all 5/8" hardware to 150 ft. lbs., and all 1/2" hardware to 100 ft. lbs.

⚠ Failure to follow the bolt tightening sequence as listed above may result in the hitch components being misaligned which could affect the performance of the hitch, or result in property damage, or serious injury.

INSTALL LATCH PIN RELEASE HANDLE

IMPORTANT: The latch pin will not function properly if handle is not installed correctly.

1. **Position Handle.** There is very little room between the bed and the frame. There is a groove in the bed structure that provides enough space to install the handle. Place the end of the handle with the holes in this groove and slide handle over frame as shown. See Figure E1.

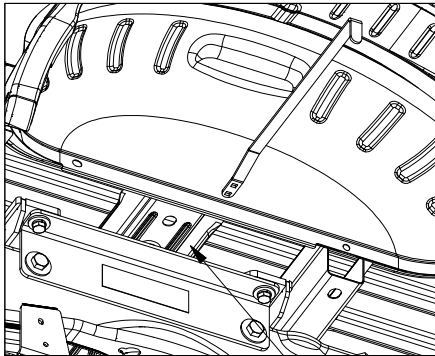

Figure E1: Driver Side Wheel Well. GROOVE IN BED FOR HANDLE TO PASS THROUGH

2. **Lock out Latch Pin.** Retract the latch pin of the center section and lock it out by pushing the mechanism toward the cab, see Figure E2. In order to prevent the mechanism from latching while attaching the handle, place a 1/4" allen wrench, thick piece of wire, or other object into the space shown on the mechanism to prevent it from latching unexpectedly, see Figure E2.

CAUTION: Serious injury can occur due to the pinch point located at the intersection of the latching mechanism and the center section.

3. **Secure Handle.** Move the handle so that the end with the holes is in a location with clearance to insert the 5/16" carriage bolts. Insert the bolts into the handle holes. Next position the handle above the latch mechanism, and insert the bolts through the holes in the latch mechanism. Secure these bolts with the 5/16" locking flange nuts, see Figure E2. Remove the object that is preventing the mechanism from latching and allow the pin to latch.

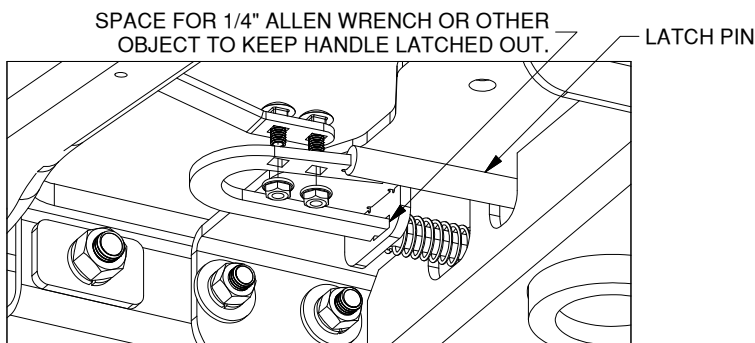

Figure E2: View looking up at latch mechanism of center section.

4. **Verify Clearance.** The general area under the truck where the handle operates contains several brake lines, wires, plugs, and other objects. Retract the latch pin with the handle attached and observe the travel path of the handle. Make sure that its travel path is clear. It may be necessary to relocate objects that interfere with the handle's operation. To operate the latch mechanism from the wheel well, pull the handle away from the truck frame and push toward the cab. This will hold the pin in the un-latched position. Move handle toward rear of truck to engage latch pin.

INSTALL SAFETY CHAIN U-BOLTS

1. **Drill Holes.** From under the bed, using a drill and small drill bit, drill a pilot hole into the bed in 4 places through the safety holes as shown in Figure F1. These holes must be perpendicular to the surface of the bed. Examine the holes from inside of the truck bed. Each set of holes should be 2" apart and each hole of a set should be the same distance from the nearest bed rib. With the pilot holes in the right position, enlarge the holes to 1/2"

SAFETY CHAIN LOCATIONS

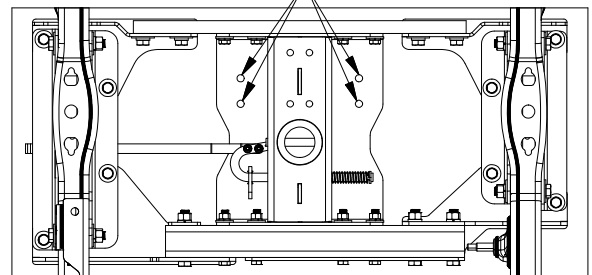

Figure F1: Bottom of truck bed looking up at hitch installation.

2. **Install U-bolts.** From the top side of the truck bed, drop a U-bolt in each set of holes.
3. **Add Springs.** Place a conical spring over each leg of the U-bolts and secure with a 1/2" lock nut, see Figure F2. Tighten the lock nut until the nut is flush with the end of the U-bolt.

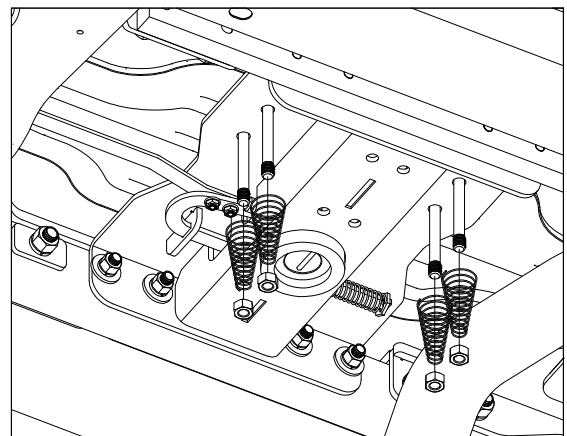

Figure F2: View looking up at U-bolt installation locations in center section.

PREPARE FOR TOWING

1. **Replace spare tire** If the spare tire was removed prior to installing the hitch, replace it at this time.
2. **Modify fender liner.** If a fender liner is present that restricts the movement of the handle, it is recommended that it be modified by cutting a relief slot or hole to allow the handle to move freely. If the liner was removed for installation, reinstall at this time.
3. **Retract the pin.** Pull the handle out all the way until it stops then slide it toward the cab. The handle should stay in this position. The latch should only be put in this open position when inverting the 2-5/16" ball or installing a B&W towing accessory.

⚠ Operating the tow vehicle while the latch is in the open position may allow the handle to come into contact with the rear tire. This may damage the tire or the handle and could lead to serious injury or death.

4. **Lubricate 2-5/16" ball.** Apply a light coating of grease to the corners on the square shank of the 2-5/16" ball.
5. **Engage pin.** Move handle toward rear of truck until the handle retracts and engages the 2-5/16" ball.

⚠ When installed properly the latch pin will pass through the 2-5/16" ball and fully engage through both walls of the hitch receiver. Failure of the pin to engage the ball and hitch properly could result in a loss of attachment between the trailer and the tow vehicle.

OPERATION & MAINTENANCE

- Always be sure that latch pin is fully engaged in the socket before towing.
- Inspect hardware connections before towing to be sure that they are secure.
- Measure and determine turning clearance with cab before towing unfamiliar trailers. Additional products for increasing turning clearance are available from B&W.
- When inverting the ball, inspect the ball's relationship with the truck's differential and drive line to ensure proper clearance. **DO NOT INVERT THE BALL WHEN HAULING HEAVY LOADS ON 2 WHEEL DRIVE TRUCKS.** A plug for the socket is available from B&W so that the ball may be removed and the socket may be covered when hauling heavy loads.
- Periodically grease the corners on the square shank of the 2-5/16" ball.