

GOOSENECK ADAPTER

MODEL #48500 (with 12" overall height), #48501 (with 15" overall height) and #48490 (with 17" overall height)
FOR USE WITH 5TH WHEEL TRAILERS

WARNING: CAREFULLY READ THE FOLLOWING INSTALLATION INFORMATION.

Capacities:

- 30,000 lb rating
- 7,500 lb Vertical Load Rating

⚠ WARNING ⚠

- **DO NOT INSTALL ON KING PIN BOXES 30" OR LONGER!** (Measure from center of king pin to center of mounting bolts.)
- NOTE: Use only hardware supplied with Gooseneck Adapter. Use of any other hardware may cause adapter to fail.

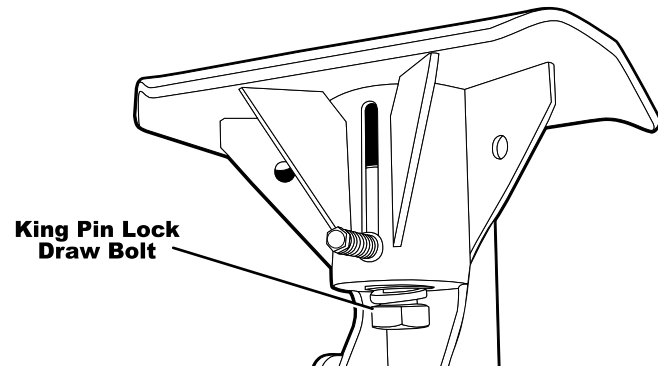
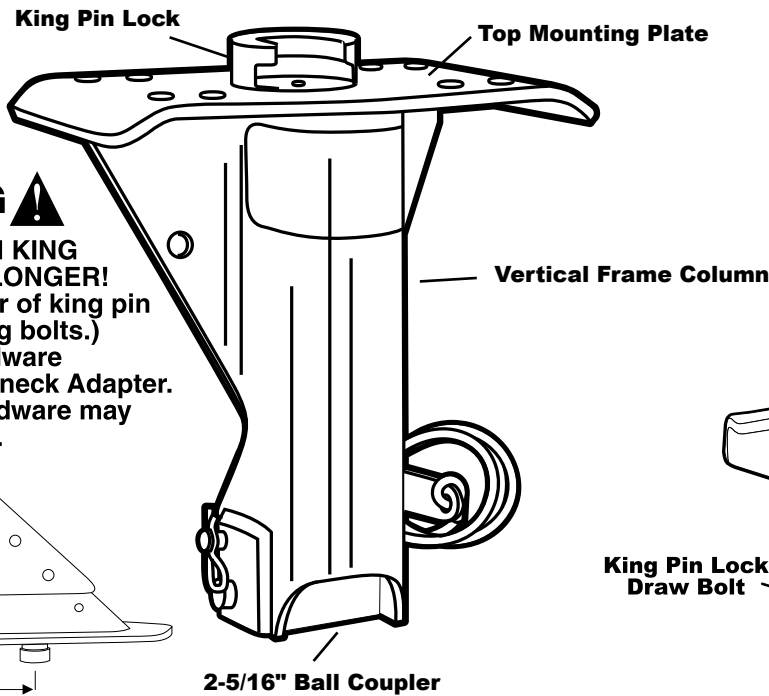
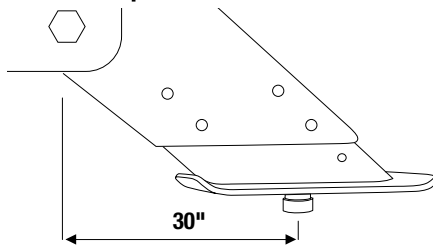

Adapter Installation

Read instructions thoroughly before starting. 7,500 lb vertical load rated.

1. Locate 1" king pin lock draw bolt on rear of unit and remove. (Fig. A)
2. Pull upward on the king pin lock until the king pin lock has emerged fully out of the top mounting plate. (Fig. A) Please note that the spring over screw will cause the lock to shift under some tension.
3. Slide king pin lock over the trailer king pin. Lift upward on the body of the adapter unit until the king pin of the trailer is brought into the body of the adapter and the top mounting plate is tight up against the trailer king pin plate. Sticker will face forward. (Fig. B)
4. Thread 1" bolt into the king pin lock. (Fig. C)
5. Torque 1" bolt to 200 ft-lb using supplied wrench. **WARNING - FAILURE TO TIGHTEN BOLT TO 200 FT-LB MAY RESULT IN DAMAGE TO TRAILER KING PIN OR ADAPTER UNIT.**
6. Locate 9/16" holes on underside of top mounting plate. Drill four holes using a 9/16" drill bit. (Fig. C)
7. Install 1/2" grade 8 bolts from bottom side of top mounting plate through to the inside of king pin box. Secure with flat washer and Lock nut on inside of king pin box. (Fig. D) **NOTE: In the event access into the king pin box is not possible due to construction, drill 1-1/2" hole into side of the king pin box using caution not to cut holes into areas where interior gussets are welded. Once bolts are secure plug holes with supplied plastic plugs.**
8. Torque nuts to 65 ft-lb **WARNING - FAILURE TO TIGHTEN NUTS TO 65 FT-LB MAY RESULT IN DAMAGE TO KING PIN BOX AND/OR ADAPTER UNIT.**
9. Install handle cable to lower deck of trailer so that it can be reached from the rear of the tow vehicle. This is a remote release for coupler when optional safety pin is not installed. **NOTE: Make sure gooseneck ball is greased before inserting into coupler.**

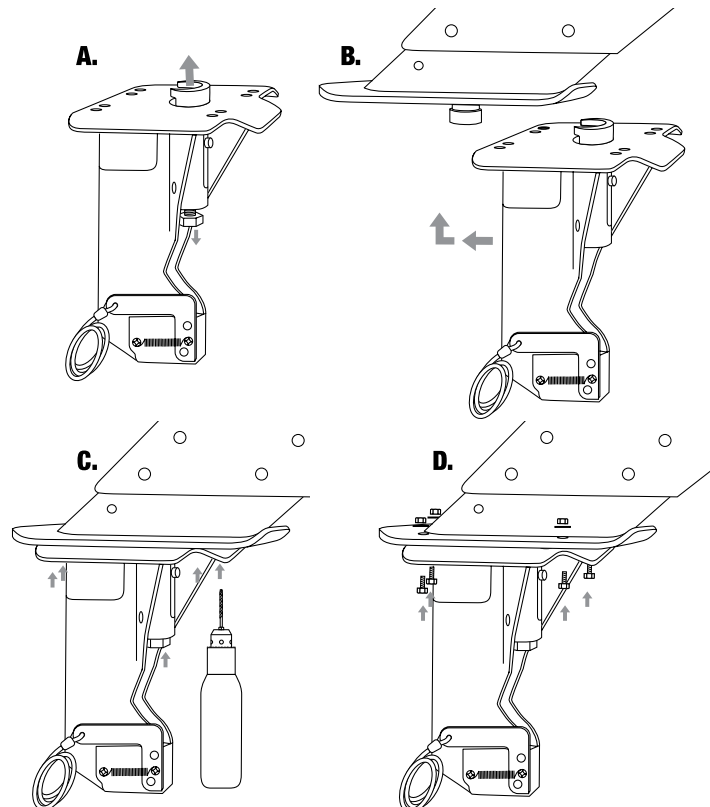

Operation

Loading Instructions:

Handle position for coupling and towing only.

Simply remove safety pin and clip, lower trailer onto ball. Coupler will unlatch and relatch automatically. Install safety pin and clip.

NOTE: before each loading procedure, grease gooseneck ball.

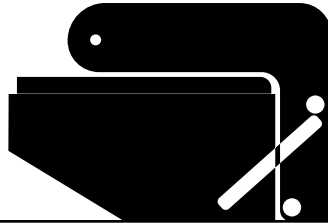

Unloading Instructions:

Handle position for uncoupling only.

Simply remove safety pin and clip. Rotate handle to this position and raise trailer off ball. Coupler will return to load position automatically. Install safety pin and clip.

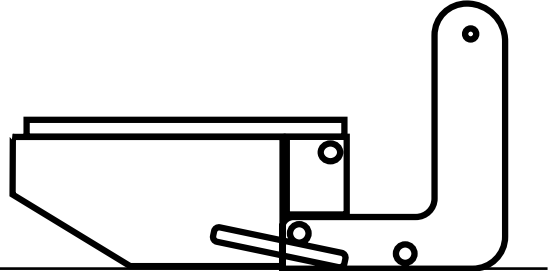

Mirror Bracket Installation (#48505)

Step 1:

After installing gooseneck unit onto the trailer king pin box, locate 3/8" mounting holes on leading edge of top mounting plate on gooseneck. (See diagram)

Step 2:

Place bracket on underside of top mounting plate and screw in 3/8" cap screws, until finger tight.

Step 3:

Torque screws to 30 ft-lbs each.

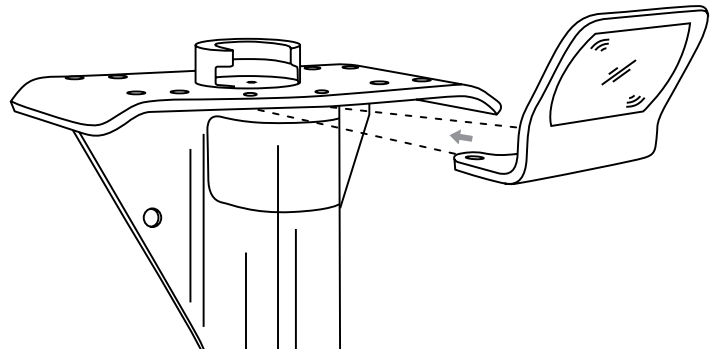

NOTICE

If product components are missing or damaged do not return to dealer, contact the manufacturer.
1-800-334-2004

The CAMCO logo, featuring the word "CAMCO" in a bold, sans-serif font inside a black parallelogram shape.

CAMCO MFG., INC.

121 Landmark Drive / Greensboro, NC 27409 / USA

1-800-334-2004

www.camco.net