

976 Series Oasis Manual RV Door Awning System

USA
SERVICE OFFICE
Dometic Corporation
2320 Industrial Parkway
Elkhart, IN 46516
574-294-2511

CANADA
Dometic Corporation
46 Zatonski, Unit 3
Brantford, ON N3T 5L8
CANADA
519-720-9578

**For Service Center
Assistance Call:**
800-544-4881

WARNING

This manual must be read and understood before installation, adjustment, service, or maintenance is performed. This unit must be installed by a qualified service technician. Modification of this product can be extremely hazardous and could result in personal injury or property damage.

AVERTISSEMENT

Lire et comprendre ce manuel avant de procéder à l'installation, à des réglages, de l'entretien ou des réparations. L'installation de cet appareil doit être effectuée par un réparateur qualifié. Toute modification de cet appareil peut être extrêmement dangereuse et entraîner des blessures ou dommages matériels.

INSTALLATION & OPERATING INSTRUCTIONS

Models

976(XX)48.000(#)
976(XX)56.100(#)
976(XX)56.000(#)
976(XX)56.100(#)

REVISION:

Form No. 3310434.001 3/07
(Replaces 3310434.000)
(French 3310439.001)
©2007 Dometic Corp.
LaGrange, IN 46761 U.S.A.

Important: These Instructions
must stay with unit.
Owner read carefully.

SAFETY INSTRUCTIONS

This manual has safety information and instructions to help users eliminate or reduce the risk of accidents and injuries.

RECOGNIZE SAFETY INFORMATION



This is the safety-alert symbol. When you see this symbol in this manual, be alert to the potential for personal injury.

Follow recommended precautions and safe operating instructions.

UNDERSTAND SIGNAL WORDS

A signal word, **WARNING** OR **CAUTION** is used with the safety-alert symbol. They give the level of risk for potential injury.

WARNING indicates a potentially hazardous situation which, if not avoided, could result in death or serious injury.

CAUTION indicates a potentially hazardous situation which, if not avoided, may result in minor or moderate injury.

CAUTION used without the safety alert symbol indicates, a potentially hazardous situation which, if not avoided, may result in property damage.

Read and follow all safety information and instructions.

GENERAL INFORMATION

WARNING

These instructions must be read and understood before installation of this awning. This kit must be installed by a Dometic Service Center or a qualified service technician. Modification of this product can be extremely hazardous and could result in personal injury or property damage.

Important: Read all of the following steps before beginning installation.

The Dometic Corporation reserves the right to modify appearances and specifications without notice.

A. Location

1. Check the wall area where the awning will be mounted to determine it is straight and there are no obstructions present. Check for a solid backing or under-structure where screws are to be used. There must be 10-1/2" of space between the top of the door and the awning rail location. See FIG. 2.
2. Before drilling, be sure that there are no obstacles inside the wall (cables, wires, gas pipes, etc.).

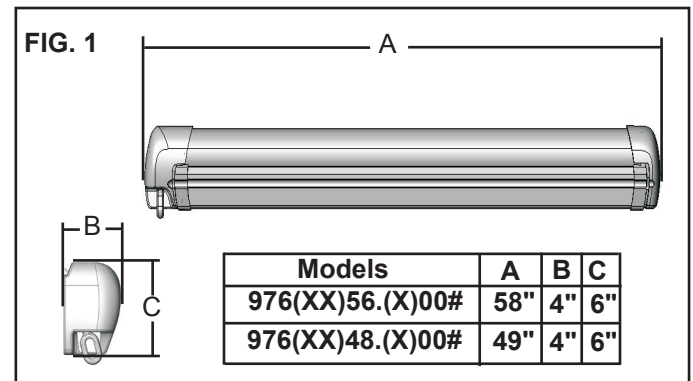

INSTALLATION INSTRUCTIONS

A. Awning Rail Installation

1. Secure awning rail to side of RV at the desired location using # 6 x 1" wood screws or self drilling sheet metal screws (not provided). Awning rail must be located at least 10-1/2" above the door. This will allow the door to open when the awning is in the extended position. Seal each screw entry hole with a silicon sealant to prevent leaks.

Important: Structural backing is required where mounting screw will be installed through sidewalls for securing Awning Rail.

B. Secure Awning

1. To aid in installation, flare end of awning rail before attempting to slide awning into rail. Slide the awning into the awning rail. See FIG. 2.

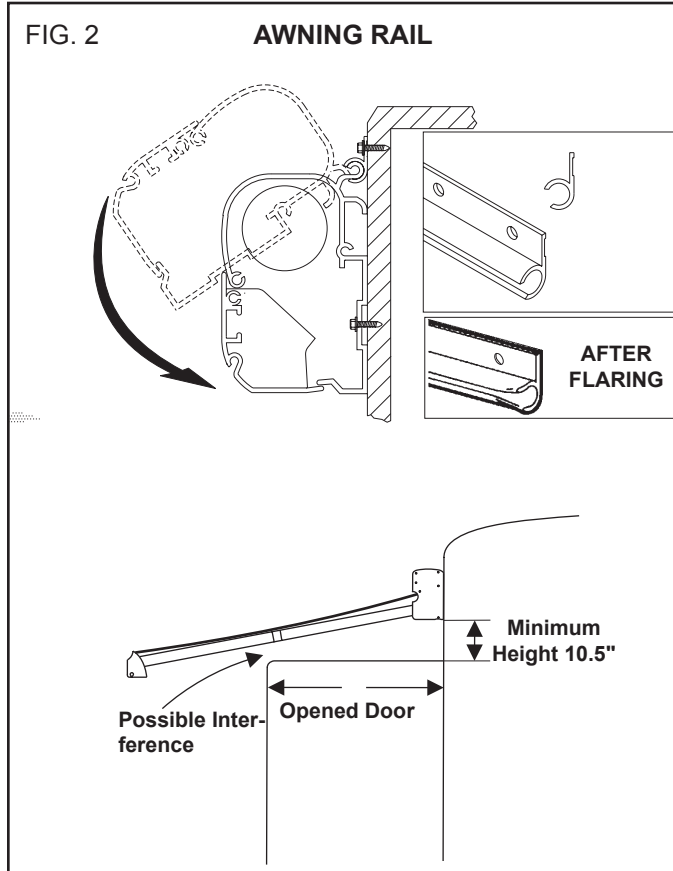

Note: Awning can be rotated up when sliding into rail.

2. Using two (2) #6 X 1/2" self drilling screws secure awning through awning rail approximately six(6) inches from each end of the rail towards the center. Open awning to its full extension. (See Operating Instructions).
3. Secure back of case to side wall of vehicle. If pre-drilled holes are not already present in back of case, using a 9/64" drill bit, (5/32" if drilling into steel) predrill holes. Secure with two (2) #10 x 1-1/2" screws (provided.) See FIG. 3.

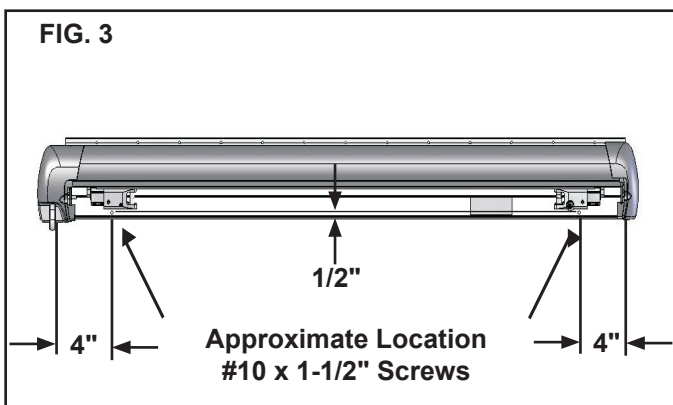

C. Other Installation Notes

1. To prevent water leakage, always use silicon sealant where each fastener enters the sidewall of the vehicle.
2. Do not over tighten fasteners. This will cause them to "strip out" and severely weaken their holding ability.

Operating Instructions

Important: We remind you that the awning is to shelter you from the sun, not from rain, wind or snow.

A. To Open

1. Place the hook of the crank into the eye of the gear and turn gear counter-clockwise to unroll the awning. See FIG. 4

B. To Close

1. Place the hook of the crank into the eye of the gear. Turn gear clockwise to roll awning up until leadrail is fully seated against case. Do not over torque when closed. Damage to awning can occur.

Note: If gear is turned counterclockwise, the awning will not seat properly against the case and damage the awning.

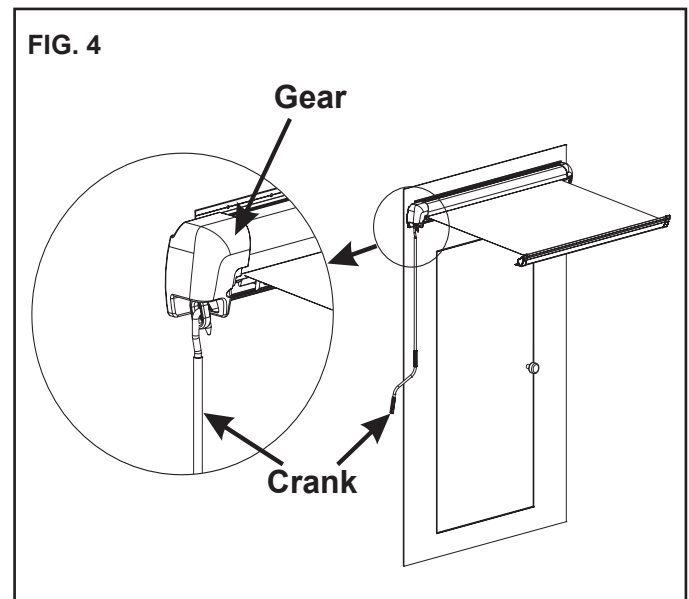

CAUTION

Fabric must roll around roller tube from bottom of roller tube. Make sure the awning is correctly closed by fully seating leadrail against case. Once fully closed, do not over torque, damage to awning can occur.

C. Maintenance

1. If heavy wind conditions exist, retract awning and place in storage position.
2. The supplied crank can be stored in a storage compartment.
3. Whenever the awning is wet while rolled up, as soon as conditions allow, roll it out and let it dry before rolling it up again. This will help prevent the formation of mildew and add greatly to the life of the awning.
4. Mildew does not form on the fabric itself, but on the accumulated dust, dirt and grime. Periodically clean vinyl or woven acrylic fabric using a mixture of **1/4 cup of dish soap and 1/4 cup of bleach mixed with 5 gallons of warm water**. Liberally slosh the mixture on the top of the fabric and roll the awning up for 5 minutes. This will apply the mixture to the bottom as well. Roll it back out and hose off with fresh water. Repeat if necessary. Allow to dry before rolling up.